

100W - 28V - 500MHz
GOLD METALLISED MULTI-PURPOSE
SILICON DMOS RF FET

FEATURES

- METAL GATE
- EXTRA LOW C_{rss}
- BROAD BAND
- SIMPLE BIAS CIRCUITS
- LOW NOISE
- HIGH GAIN

APPLICATIONS

- HF/VHF/UHF COMMUNICATIONS
from DC to 500 MHz

ABSOLUTE MAXIMUM RATINGS
($T_{CASE} = 25^{\circ}C$ unless otherwise stated)

P_D	Power Dissipation	292W
BV_{DSS}	Drain-source breakdown voltage	70V
V_{GSS}	Gate-source voltage	$\pm 20V$
I_D	Drain Current	15A
T_{stg}	Storage temperature	65 to $150^{\circ}C$
T_j	Maximum operating junction temperature	$200^{\circ}C$
$R_{\theta J-case}$	Thermal resistance junction-case	Max. $0.6^{\circ}C/W$

ELECTRICAL CHARACTERISTICS ($T_{CASE} = 25^{\circ}C$ unless otherwise stated)

Parameter	Test Conditions	Min.	Typ.	Max.	Unit
<u>PER SIDE</u>					
BV_{DSS}	Breakdown voltage, drain source $V_{GS}=0$ $I_D=100mA$	70			Vdc
I_{DSS}	Drain leakage current $V_{DS}=28V$ $V_{GS}=0$			3	mAdc
I_{GSS}	Gate leakage current $V_{GS}=20V$ $V_{DS}=0$			1	μ Adc
$V_{GS(th)}$	Gate threshold voltage $I_D=10mA$ $V_{DS}=V_{GS}$	1		7	Vdc
gfs	Transconductance (300 μ s pulse) $V_{DS}=10V$ $I_D=3A$	2.4			Mhos
<u>TOTAL DEVICE</u>					
G_{PS}	Common source power gain $P_O=100W$	10			dB
η	Drain efficiency $V_{DS}=28V$ $I_{DQ}=1.2A$	50			%
VSWR	Load mismatch tolerance $f=500MHz$	20:1			
<u>PER SIDE</u>					
C_{iss}	Input capacitance $V_{DS}=0V$ $V_{GS}=-5V$ $f=1MHz$			180	pF
C_{oss}	Output capacitance $V_{DS}=28V$ $V_{GS}=0$ $f=1MHz$			90	pF
C_{rss}	Reverse transfer capacitance $V_{DS}=28V$ $V_{GS}=0$ $f=1MHz$			7.5	pF

DIMENSIONS

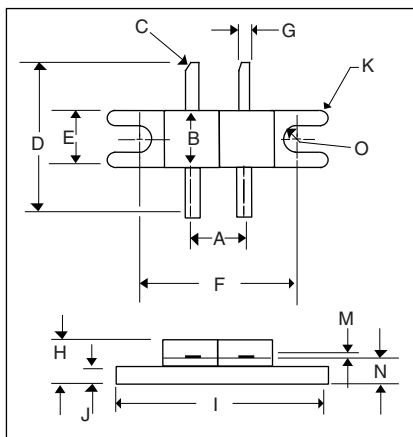

DM	Millimeter	TOL	Inches	TOL
A	6.45	.13	.254	.005
B	6.35	.13	.250	.005
C	45°	5°	45°	5°
D	16.51	.76	.650	.030
E	6.48	.13	.255	.005
F	18.42	.13	.725	.005
G	1.52	.13	.060	.005
H	4.06	.25	.160	.010
I	24.77	.13	.975	.005
J	1.52	.13	.060	.001
K	0.81R	.13	.032R	.005
M	.010	.03	.004	.001
N	2.16	.13	.085	.005
O	1.65R	.03	.065R	.005

HAZARDOUS MATERIAL WARNING

The ceramic portion of the device between leads and metal flange is beryllium oxide. Beryllium oxide dust is highly toxic and care must be taken during handling and mounting to avoid damage to this area. THESE DEVICES MUST NEVER BE THROWN AWAY WITH GENERAL INDUSTRIAL OR DOMESTIC WASTE.

U.S. PATENTS 5,121,176 & 5,179,032
GLOBAL PATENTS PENDING

